

Air Conditioning

Product Information

PEA-RP200GAQ (Three Phase)

Power Inverter Heat Pump

Large Capacity Ceiling Concealed Ducted System

Making a
World of
Difference

Mr.SLIM™



Our wide range of Power Inverters offer customers high seasonal efficiency, advanced control options and quiet operation, whilst providing greater flexibility and ease of installation.

Key Features

- Static pressure of up to 150Pa
- Long pipe run
- Flexible ducting design



Air Conditioning | Heating
Ventilation | Controls



Air Conditioning

Product Information

PEA-RP200GAQ (Three Phase) Power Inverter Heat Pump

Large Capacity Ceiling Concealed Ducted System

Making a
World of
Difference

PEA-RP - INDOOR UNITS		PEA-RP200GAQ ^③ Three Phase
CAPACITY (kW)	Heating (nominal)	22.4 (9.5-25.0)
	Cooling (nominal)	19.0 (9.0-22.4)
	Heating (UK)	19.05 (8.1-21.25)
	Cooling (UK)	17.5 (8.3-20.6)
SHF (nominal & UK)		0.81
COP / EER (nominal)		3.23 / 2.94
ENERGY LABEL Heating/Cooling (nominal)		B / C
AIRFLOW (l/s) Lo-Hi		867-1084
PIPE SIZE mm (in) Gas		28.58 (1 1/8")
Liquid		9.52 (3/8")
EXTERNAL STATIC PRESSURE (pa)		150
SOUND PRESSURE Level (dBA) (50Pa) Lo-Hi		48-51
DIMENSIONS (mm) Width x Depth x Height		1400 x 634 x 400
WEIGHT (kg)		70
Electrical Supply		380-415v, 50Hz
PHASE		Three
POWER INPUT (kW) Nominal / UK		1.00 / 0.89
STARTING CURRENT (A)		5.6
RUNNING CURRENT (A) [MAX]		2.0 [2.4]
FUSE RATING (BS88) - HRC (A)		6
MAINS CABLE No. Cores		5
INTERCONNECTING CABLE No. Cores		3

DIMENSIONS

Front View

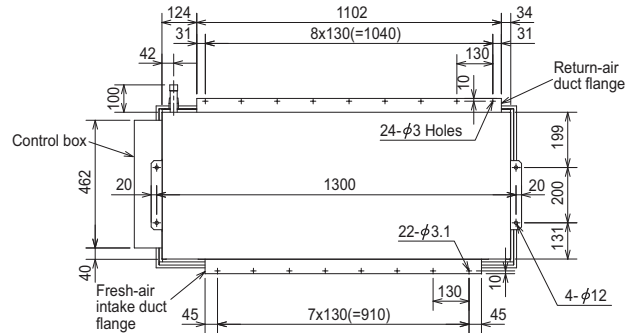

Upper View

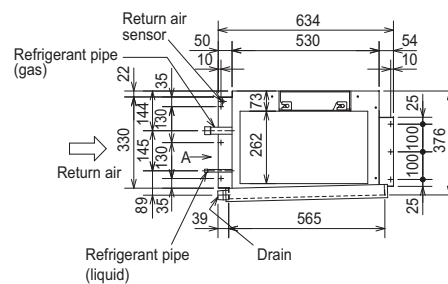

Back View

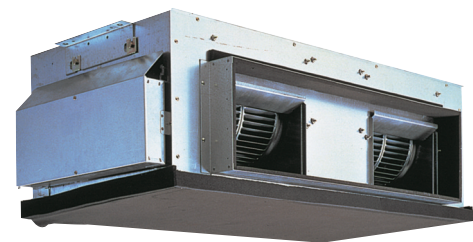
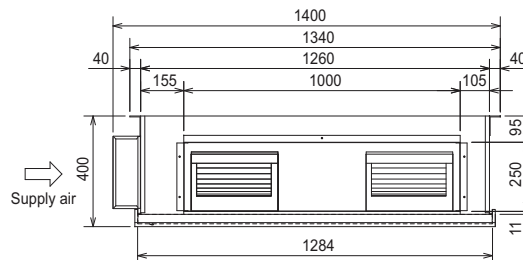

PUHZ-ZRP - OUTDOOR UNITS		PUHZ-ZRP200YKA ^③ Three Phase
SOUND PRESSURE LEVEL (dBA) Heating/Cooling		62 / 59
WEIGHT (kg)		135
DIMENSIONS (mm) Width x Depth x Height		1050 x 330 + 40 x 1338
ELECTRICAL SUPPLY		380-415v, 50Hz
PHASE		Three
SYSTEM POWER Heating/Cooling (nominal)		6.94 / 6.46
INPUT (kW) Heating/Cooling (UK)		5.55 / 5.71
STARTING CURRENT (A)		5
RUNNING CURRENT (A) Heating/Cooling [MAX]		8.63 / 8.94 [19]
FUSE RATING (BS88) - HRC (A)		20
MAINS CABLE No. Cores		5
MAX PIPE LENGTH (m)		100
MAX HEIGHT DIFFERENCE (m)		30
CHARGE R410A (kg) - 30m		7.1

^③ Three Phase



Telephone: 01707 282880

email: air.conditioning@meuk.mee.com web: www.airconditioning.mitsubishielectric.co.uk

UNITED KINGDOM Mitsubishi Electric Europe Living Environmental Systems Division
Travellers Lane, Hatfield, Hertfordshire, AL10 8XB, England General Enquiries Telephone: 01707 282880 Fax: 01707 278881

IRELAND Mitsubishi Electric Europe Westgate Business Park, Ballymount, Dublin 24, Ireland
Telephone: Dublin (01) 419 8800 Fax: Dublin (01) 419 8890 International code: (003531)

Country of origin: United Kingdom - Japan - Thailand - Malaysia. ©Mitsubishi Electric Europe 2015. Mitsubishi and Mitsubishi Electric are trademarks of Mitsubishi Electric Europe B.V. The company reserves the right to make any variation in technical specification to the equipment described, or to withdraw or replace products without prior notification or public announcement. Mitsubishi Electric is constantly developing and improving its products. All descriptions, illustrations, drawings and specifications in this publication present only general particulars and shall not form part of any contract. All goods are supplied subject to the Company's General Conditions of Sale, a copy of which is available on request. Third-party product and brand names may be trademarks or registered trademarks of their respective owners.



Note: The fuse rating is for guidance only. Please refer to the relevant databook for detailed specification. It is the responsibility of a qualified electrician/electrical engineer to select the correct cable size and fuse rating based on current regulation and site specific conditions. Mitsubishi Electric's air conditioning and heat pump systems contain fluorinated greenhouse gases R410A, R407C and R134a.



www.greengateway.mitsubishielectric.co.uk

Mitsubishi Electric UK's commitment
to the environment



Follow us @meuk_Jes
Follow us @green_gateway



Mitsubishi Electric
Living Environmental Systems UK



mitsubishielectric2

Effective as of April 2015